

Front Suspension:

Ride Height: _____
 Camber: _____
 Toe: _____
 Anti-Roll Bar: _____
 Arm Type: _____
 Tower Type: _____
 Wheelbase Shim: _____
 Wheel Hex: _____
 Steering Block Type: _____
 Caster Block: -2° -1° 0° +1° +2°
 Chassis Brace Material: _____
 Top Plate Brace Material: _____
 Front Axles: CVA DCV
 Notes: _____

Lower Brace Type: Fixed Pivot



Ball Stud Spacing: _____

Arm Mount A: 1° 0.5°
 Gray Black



Arm Mount B: 1° 0.5°
 Gray Black



Diff Height: _____
 +3
 +2
 +1
 +0

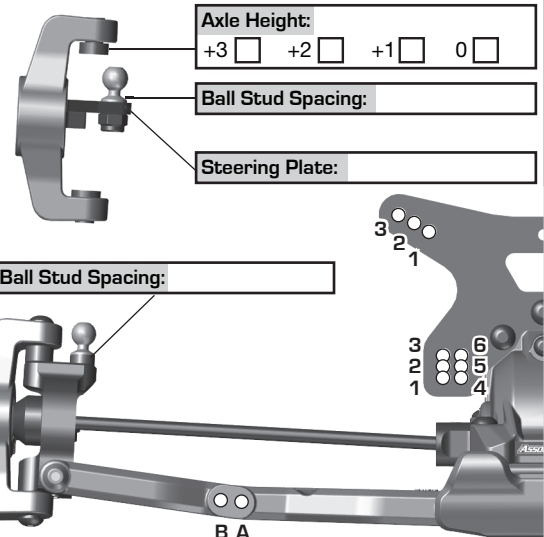

Rear Suspension:

Ride Height: _____
 Camber: _____
 Anti-Roll Bar: _____
 Arm Type: _____
 Tower Type: _____
 Wheelbase Shim: _____
 Wheel Hex: _____
 Hub Type: _____
 Drive Shaft Type: _____
 Chassis Brace Material: _____
 Upper Chassis Brace Material: _____
 Hub Spacing: Fwd Mid Back
 Notes: _____

Lower Brace Type: Fixed Pivot



Rear Chassis Brace Screws: _____

Arm Mount C: 1° 0.5°
 Gray Black



Arm Mount D: 1° 0.5°
 Gray Black



Axle Height: _____
 ▼0 3▲ +3
 ▼1 2▲ +2
 ▲1 2▼ +1
 ▲0 3▼ +0

Diff Height: _____
 +3
 +2
 +1
 +0

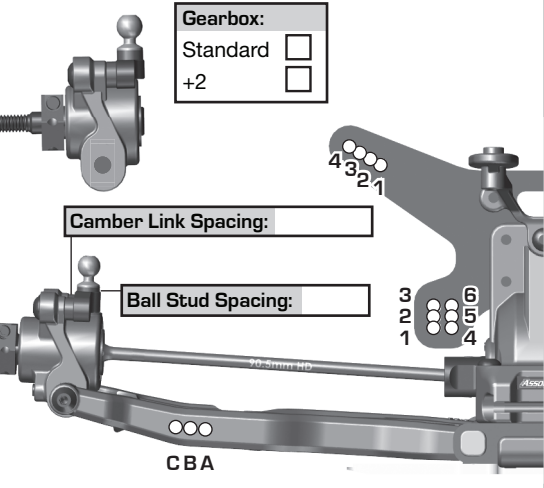

Electronics:

Radio: _____ Servo: _____
 EPA: Throttle: _____ % Brake: _____ %
 ESC: _____
 ESC Settings: _____
 Motor / Wind: _____ Timing: _____
 Pinion: _____ Spur: _____
 Motor Position: Forward: Back:
 Battery Position: _____
 Back 1 2 3 4 5 Forward
 Battery: _____ Weight: _____
 Notes: _____

Differential:

	Front	Center	Rear
Fluid:	_____	_____	_____
Gears:	_____	_____	_____
Type:	_____	_____	_____

Notes: _____

Slipper Clutch:

Type: _____
 # of Pads: _____
 Setting: _____
 Notes: _____

Shocks:

	Front	Rear
Piston:	_____	_____
Thickness:	_____	_____
Fluid:	_____	_____
Spring:	_____	_____
Limiters: Int: _____ Ext: _____ Int: _____ Ext: _____		
Stroke:	_____	_____
Eyelet:	_____	_____
Cup Offset: 0 <input type="checkbox"/> +5 <input type="checkbox"/> +9 <input type="checkbox"/> 0 <input type="checkbox"/> +5 <input type="checkbox"/> +9 <input type="checkbox"/>		
Kashima Bodies: <input type="checkbox"/> Chrome Shafts: <input type="checkbox"/> Machined Spacers: <input type="checkbox"/>		

Notes: _____

Track Info:

Size: _____
 Surface: _____
 Traction: _____
 Moisture: _____
 Condition: _____
 Temperature: _____
 Notes: _____

Tires:

Front Tires: _____
 Front Compound: _____
 Front Insert: _____
 Rear Tires: _____
 Rear Compound: _____
 Rear Insert: _____
 Wheel (F/R): _____
 Notes: _____

Body, Weight:

Body: _____
 Front Wing: _____
 Rear Wing: _____
 Rear Wing Mount: 0 -2
 Wing Angle: 0° 3° 6°
 Chassis Length: _____
 Total Vehicle Weight: _____
 Notes: _____

Vehicle Comments:

Notes: _____

